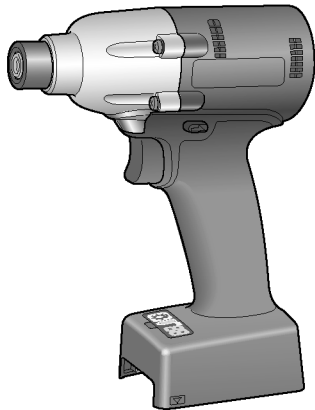

Service Manual

Cordless Impact Driver

EYFLA1A**EYFLA2A**

Cordless Impact Wrench

EYFLA2Q**EYFLA3J****North America****⚠ WARNING**

This service literature is designed for experienced repair technicians only and is not designed for use by the general public. It does not contain warnings or cautions to advise non-technical individuals of potential dangers in attempting to service a product. Products powered by electricity should be serviced or repaired only by experienced professional technicians. Any attempt to service or repair the product or products dealt with in this service information by anyone else could result in serious injury or death.

IMPORTANT SAFETY NOTICE

There are special components used in this equipment which are important for safety. These parts are marked by \triangle in the Schematic Diagrams, Circuit Board Diagrams, Exploded views and Replacement Parts List. It is essential that these critical parts should be replaced with manufacture's specified parts to prevent shock, fire or other hazards. Do not modify the original design without permission of manufacturer.

TABLE OF CONTENTS

	Page		Page
1. Warning	2	6. Measurements and Adjustments	19
2. Specifications	2	7. Schematic Diagram	20
3. Troubleshooting guide	3-5	8. Wiring Connection Diagram	21
4. Service Fixture and Adjustment	6-10	9. Exploded View & Replacement Parts List	22-29
5. Disassembly / Assembly Instructions	11-18		

Panasonic

©2008 Matsushita Electric Works, Ltd.
All rights reserved. Unauthorized copying
and distribution is a violation of law.

Model EYFLA1/EYFLA2/EYFLA3**1. WARNING****Caution:**

- Pb free solder has a higher melting point than standard solder; Typical the melting point is 50 - 70° F (30 - 40°C) higher. Please use a soldering iron with temperature control and adjust it to 750 ±20° F (400 ± 10°C). In case of using high temperature soldering iron, please be careful not to heat too long.
- Pb free solder will tend to splash when heated too high (about 1100° F / 600°C).

2. SPECIFICATIONS**MAIN UNIT**

Model		EYFLA1	EYFLA2		EYFLA3
		A	A	Q	J
Motor		10.8V DC			
Chuck size	Single-ended	9-9.5 mm (23/64" – 3/8")	9-9.5 mm (23/64" – 3/8")	9-9.5 mm (23/64" – 3/8")	12.7 mm (1/2")
	Double-ended	12 mm (15/32")	12 mm (15/32")		
No load speed (rpm)	Stage	1 : 0- 950 min ⁻¹ 2 : 0-1000 min ⁻¹ 3-5 : 0-1050 min ⁻¹ 6 : 0-1300 min ⁻¹ 7 : 0-1450 min ⁻¹ 8 : 0-1550 min ⁻¹ 9-30F:0-2300 min ⁻¹	1 : 0- 1300 min ⁻¹ 2 : 0-1450 min ⁻¹ 3 : 0-1550 min ⁻¹ 4-30F:0-2300 min ⁻¹		0-2300 min ⁻¹
Impact per minute (rpm)	Stage	1 : 0- 1900 min ⁻¹ 2 : 0-1950 min ⁻¹ 3-5 : 0-2100 min ⁻¹ 6 : 0-2500 min ⁻¹ 7 : 0-2800 min ⁻¹ 8 : 0-3000 min ⁻¹ 9-30F:0-4000 min ⁻¹	1 : 0- 2500 min ⁻¹ 2 : 0-2800 min ⁻¹ 3 : 0-3000 min ⁻¹ 4-30F:0-3600 min ⁻¹		0-3000 min ⁻¹
Maximum torque		40Nm (408kgf-cm, 354in-lbs.)	90Nm (918kgf-cm, 796in-lbs.)		120Nm (1224kgf-cm, 1062in-lbs.)
Torque control function operating range		3-22Nm (31-2244kgf-cm, 27-195in-lbs.)	6-30Nm (61-306kgf-cm, 53-266in-lbs.)		16-53Nm (163-540kgf-cm, 142-409in-lbs.)
Overall length		158mm (6-7/32")		164mm (6-7/16")	
Weight (with battery pack EYFB30)		1.3 kg (2.8lbs.)			1.35 kg (2.9lbs.)

3. TROUBLESHOOTING GUIDE (Refer to WIRING CONNECTION DIAGRAM)

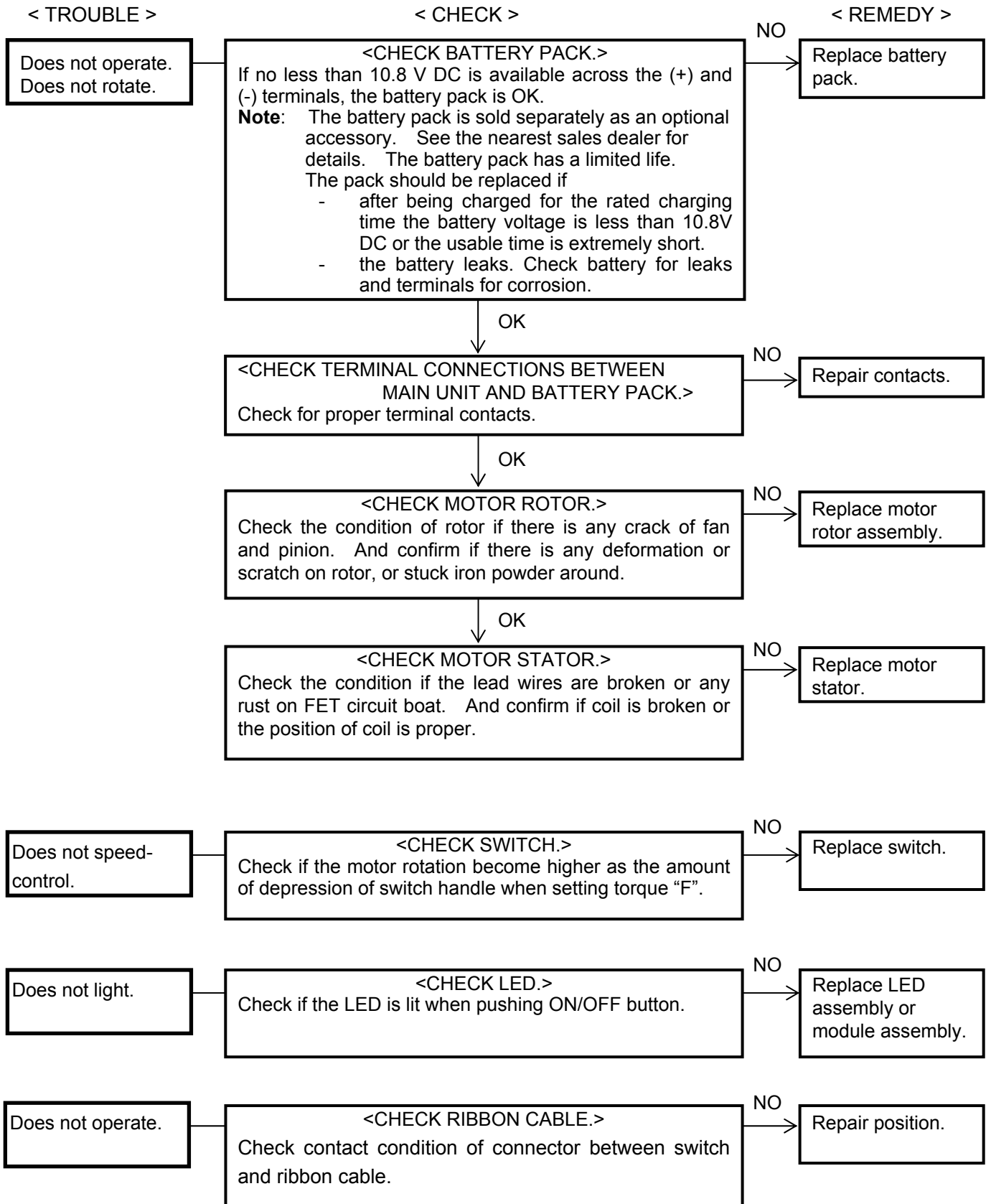

Model EYFLA1/EYFLA2/EYFLA3

< TROUBLE >

< CHECK >

< REMEDY >

Weakness of blowing.

<CHECK ANVIL.>

Check wear condition of anvil. If no less than 1mm from the corner at (A) side or 0.5mm from the corner at (B) side, anvil is OK.

Driving shaft assembly

Anvil

Check wear condition

A

B

less than 1mm

less than 0.5mm

NO → Replace anvil.

OK ↓

<CHECK DRIVING HAMMER.>

Confirm if hammer rotates smoothly when moving it by fingers.

Check wear condition of hammer. If no less than 2mm from the corner at (C) side or 1mm from the corner at (D) side, hammer is OK.

Hammer

D

C

less than 1mm

less than 2mm

NO → Replace hammer.

Operation panel does not indicate correctly. Does not work the button.

<CHECK MODULE ASSEMBLY.>

Check if there are foreign substances stuck around module assembly. Follow the explanation "CHECK PART IDENTIFY PROCEDURE".

NO → Replace module assembly.

< TROUBLE >

< CHECK >

< REMEDY >

Does not stop when automatic power-off function is not activated.

<CHECK F/R SELECTOR LEVER.>
Check if F/R selector handle is set on FORWARD side. If it is set on REVERSE side, the unit does not stop when automatic power-off function is not activate.

NO → Set F/R selector handle on FORWARD side.

OK

<CHECK TORQUE SETTING.>
Confirm torque setting whether the display shows the number from 1 and 30. (If “F” indicates, the torque control function is off and the automatic power-off function is not activate.)

NO → Set torque selecting the number from 1 and 30.

OK

<CHECK HAMMER and ANVIL.>
Check wear condition of anvil and hammer. (Please see the procedure explained on the previous page.)

NO → Replace hammer and anvil.

OK

<CHECK LED ASSEMBLY.>
Check if the connector is inserted into module assembly firmly.

NO → Repair connector of LED assembly.

OK

<CHECK LED ASSEMBLY.>
Check contact condition of connector between switch and LED assembly.

NO → Replace LED assembly.

OK

<CHECK HOUSING.>
Check if fixing rubber is located on Housing B.

NO → Replace Housing AB set.

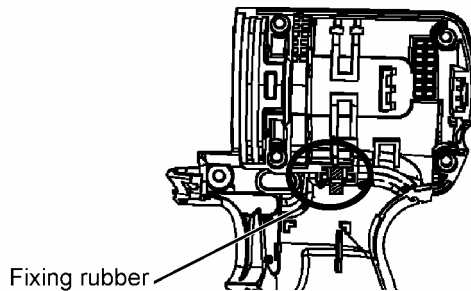

OK

<CHECK MODULE ASSEMBLY.>
Check if there are foreign substances stuck around module assembly. Follow the explanation “CHECK PART IDENTIFY PROCEDURE”.

NO → Replace module assembly.

4. SERVICE FIXTURE AND ADJUSTMENT
4.1. CHECK PARTS IDENTIFY PROCEDURE

Phenomenon		Pre-check Corrective action	Check order of priority (1:prioritymost)					
Problem	LED lights on Control panel.		Stator block	Battery pack	Ribbon cable	Switch assembly	Main PCB	LED assembly
<p>Operation stops in an instant even the switch handle is depressed.</p> <p>Does not operate.</p> <p>Operation stops in a moment.</p>	No indication		6	1	4	3	2	5
	Blinking of battery indication lamp. (3 levels)			1			2	
	E1 [Setting error.]	Re-initialize the tool using the remote control.					1	
	E2 [The battery pack is too hot.]	Stop work and allow the battery pack to cool before resuming use of the tool.		1			2	
	E3 [Motor is too hot to operate.]	Stop work and allow the tool to cool before resuming use.	1		3		2	
	E5 [Motor failure etc]	Attach the hexagonal socket and confirm the smooth rotation by hand.	1		2		3	
	E6 [Sensor malfunction, failure etc.]	Confirm if the screws on the fixation cover are tightened firmly. Confirm if the hammer or anvil are not worn out. Confirm if the fixing rubber is attached with the housing B.	4		3		2	1
	E7 [Module malfunction, failure etc.]						1	
	The number on your selection of torque clutch setting.	Attach the hexagonal socket and confirm the smooth rotation by hand.	1		2		3	

Model EYFLA1/EYFLA2/EYFLA3

Phenomenon		Pre-check Corrective action	Check order of priority (1:prioritymost)					
Problem	LED lights on Control panel.		Stator block	Battery pack	Ribbon cable	Switch assembly	Main PCB	LED assembly
Blinking "E4" on the control panel while operating.	E4 [The contacts that connect the battery pack and tool are dirty. The battery pack has not been properly inserted into the tool.]	Remove any dirt. Insert the battery pack firmly into the tool		1			2	
	E4 [The pins on either the tool or battery pack has worn down.]	Replace the battery pack.		1				
Pulsatory motion and stops.	The number on your selection of torque clutch setting.	Attach the hexagonal socket and confirm the smooth rotation by hand.	1		2	3	4	
One direction only either forward rotation or reverse rotation.	The number on your selection of torque clutch setting.	-				1	2	
Rotation stops while depressing the switch handle slowly.	The number on your selection of torque clutch setting.	-				1		
Operation does not start in an instant.	The number on your selection of torque clutch setting.	-		1	4	2	3	
Does not rotate fully even the switch handle is depressed all the way.	The number on your selection of torque clutch setting.	EYFLA1: 1-8 EYFLA2: 1-3 EYFLA3: any numbers (1-30)	4	3	5	1	2	
LED does not light up.	The number on your selection of torque clutch setting.	Confirm if the switch handle is depressed before pressing LED light ON/OFF button.				3	2	1
Remote control does not work.	-	Confirm if the battery comes its life.					1	

Model EYFLA1/EYFLA2/EYFLA3

CHECK POINT	
Motor stator	1. If there is continuity between (+) lead wire and motor coil “U” on FET, motor stator should be defective.
	2. If there is continuity between (-) lead wire and motor coil “U” on FET, motor stator should be defective.
	3. Operation test.
Battery pack	See in detail at TROUBLESHOOTING GUIDE.
Ribbon cable	Visual inspection for breakage.
Switch assembly	Operation test.
Module assembly	Operation test.
LED	ON/OFF operation test.
Motor rotor assembly	1. No wear, scratch and damage.
	2. No breakage of fan and seizure on bearing.
	3. No discoloration of coil.

4.2. INITIALIZING and SETTING

NOTE:

- This section explains how to revert all tool settings to their default values at the time of shipment from the factory.
- The error display will be turned off.

■ INITIALIZING ALL SETTINGS.

1. Set the tool to configuration mode.
(See the next procedure ■ SETTINGS THE TOOL TO CONFIGURATION MODE.)

2. Press the format button.

a) The control panel will begin flashing.

DISPLAY: The letter “F” flashes on and off.

BATTERY INDICATION LAMP: The upper and lower bars of the battery flash on and off.

3. Press the OK button to accept the selected setting.

a) The control panel will stop flashing and light up.

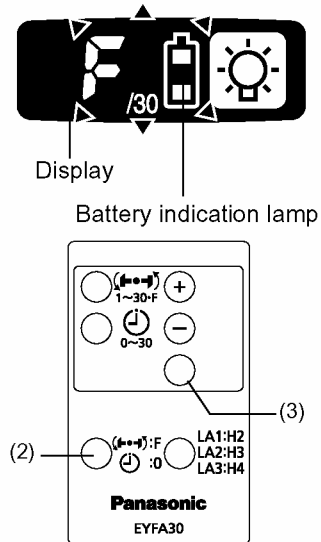

■ SETTINGS THE TOOL TO CONFIGURATION MODE.

1. Turn off the control panel.

If the control panel is on, remove and then reinsert the battery pack.

2. Engage the switch while pushing the button and then release both the button and the switch.

a) After all the LED lamps have turned off, the control panel will flash and change to configuration mode.

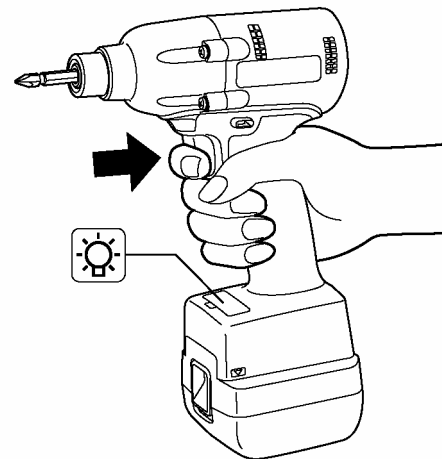

Model EYFLA1/EYFLA2/EYFLA3

■ CONFIGURING THE TORQUE CLUTCH SETTING.

1. Press the ⊕ and ⊖ buttons to select the clutch setting that is appropriate for the work being performed.

a) "F" indicates that the torque control function is off.

b) You can select from 30 torque clutch settings (1 to 30).

2. Press the OK button to accept the selected torque clutch setting.

a) The control panel will stop flashing and light up.

NOTE: You must press the OK button in order for the selected setting to take effect.

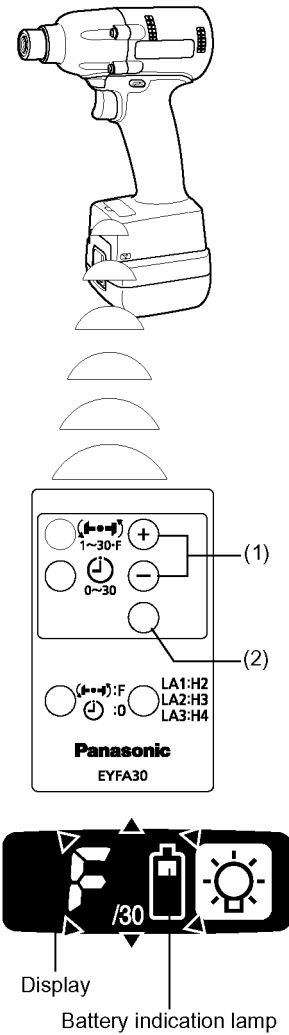

5. DISASSEMBLY/ASSEMBLY INSTRUCTIONS

5.1. DISASSEMBLY INSTRUCTIONS

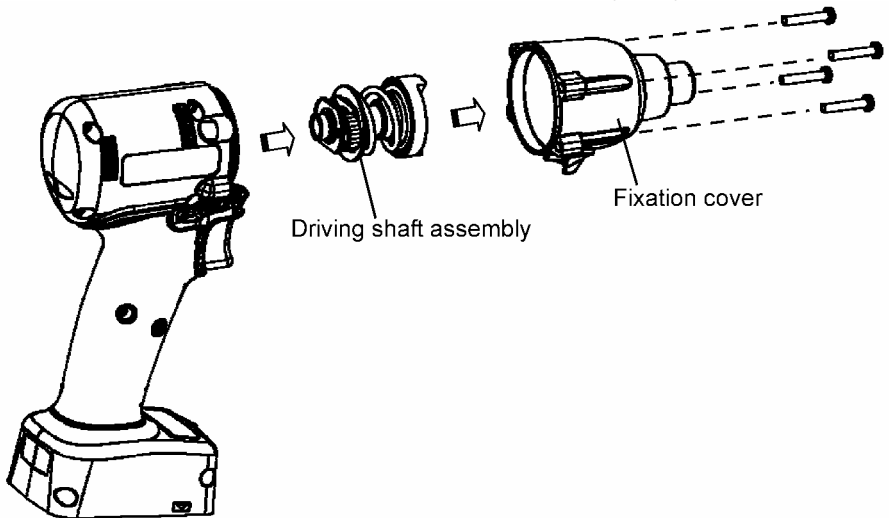
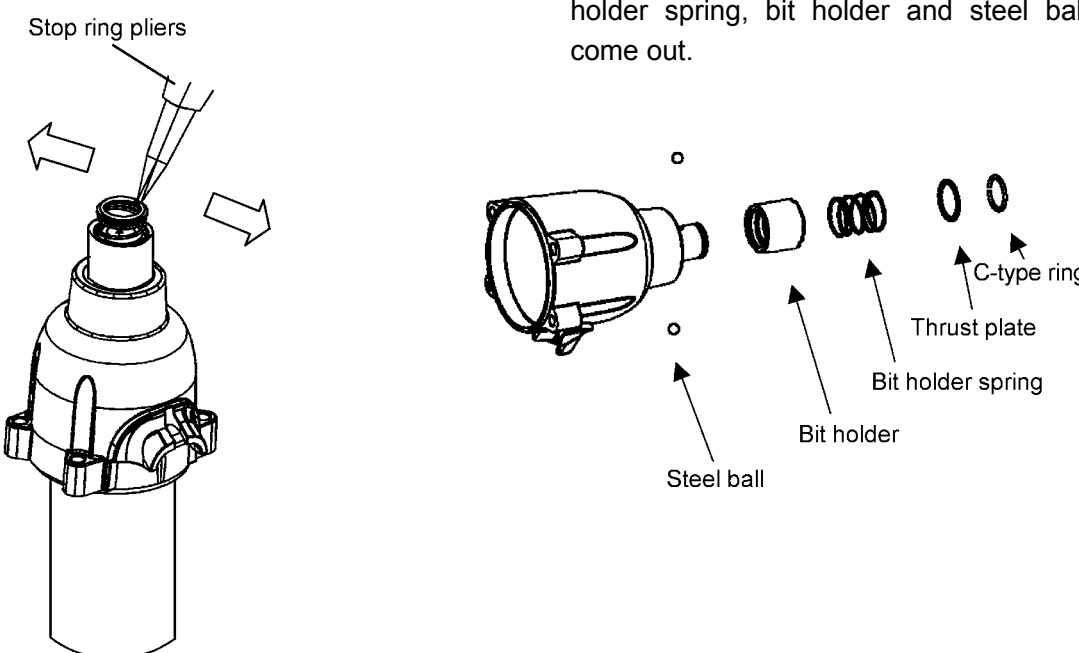
Ref. No. 1A	Procedure 1A	Removal of the Housings
		<ol style="list-style-type: none"> 1. Remove four screws where tightening fixation cover. 2. Pull off the fixing cover assembly. 3. Once removing the fixing cover, the driving shaft assembly may come out. 
Ref. No. 1B	Procedure 1A→1B	Removal of bit holder. (EYFLA1A and EYFLA2A only)
		<ol style="list-style-type: none"> 1. Remove C-type ring by the stop ring pliers. 2. Once removing C-type ring, thrust plate, bit holder spring, bit holder and steel balls may come out. 

Model EYFLA1/EYFLA2/EYFLA3

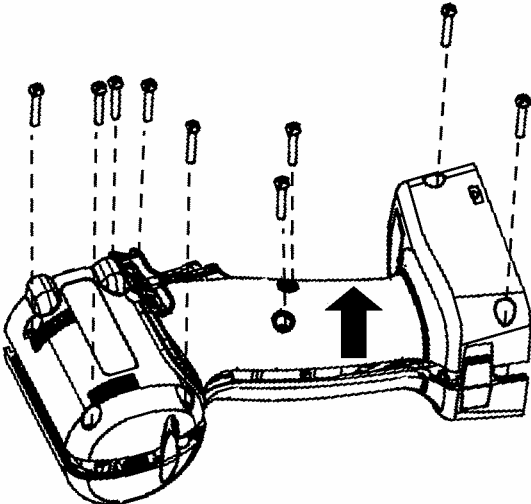
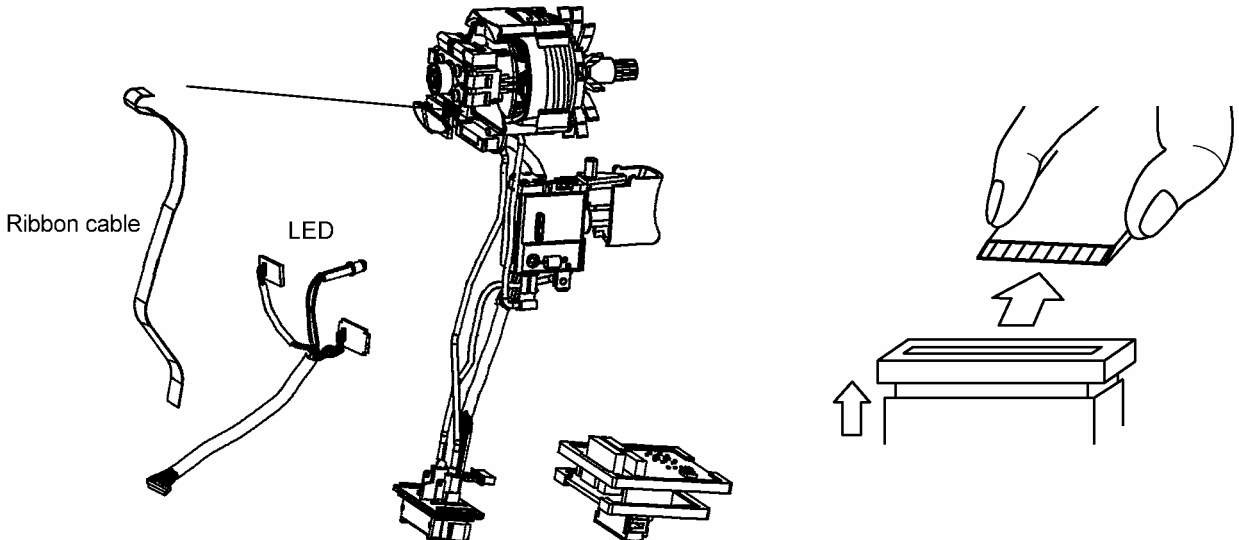
Ref. No. 1C	Procedure 1A→1B→1C	Removal of housing.
		<ol style="list-style-type: none">1. Remove nine housing screws.2. Then open the housing A and B. <p>NOTE: When opening the housings, make sure that the main PCB is on the housing A.</p> <p>If the main PCB sticks in the housing B and pull it out from the housing A, the ribbon cable may be defected.</p> <p>NOTE: The housing A and B is tightened as the motor mounting base is joint fitting.</p> <p>Hold the housing B and take it out vertically.</p>
Ref. No. 1D	Procedure 1A→1B→1C→1D	Removal of ribbon cable.
		<ol style="list-style-type: none">1. Slightly lift up the connector. <p>NOTE: Do not pull the connector firmly because it is not able to take out completely.</p> <ol style="list-style-type: none">2. Take out the ribbon cable.

Ref. No. 1E	Procedure 1A→1B→1C→1D→1E	Removal of Motor assembly.
-------------	--------------------------	----------------------------

1. Separate the motor assembly from the driving shaft assembly.
2. Take out the motor rotor assembly from the motor stator.

NOTE: Make sure not to damage the magnet by motor rotor.

NOTE: Make sure not to scratch FET circuit by motor rotor.

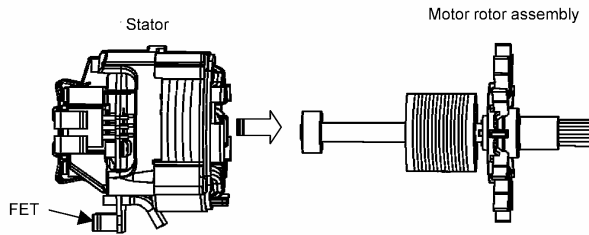

Ref. No. 1F	Procedure 1A→1B→1C→1D→1E→1F	Removal of Driving shaft assembly.
-------------	-----------------------------	------------------------------------

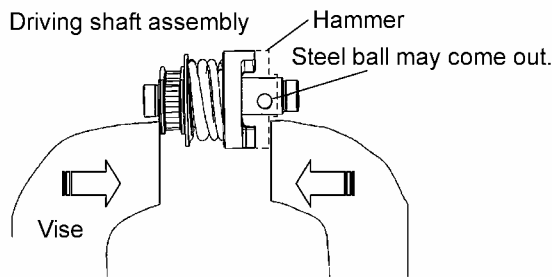

1. Take out two steel balls by pressing with vise.

NOTE: Set another hammer on the reverse side next to the original hammer.

When pressing the driving shaft assembly by vise, do not take out the planet gear. If failure to do so it may crack the shaft.
2. Pull out two steel balls.
3. After removing steel balls, the assembled parts can be removed one after another.

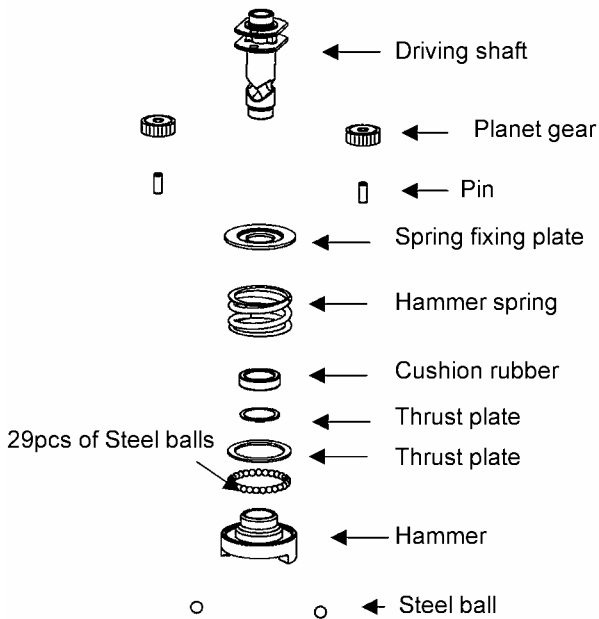

Hammer ⇒ 29pcs of Steel balls ⇒ Thrust plate ⇒ Thrust plate ⇒ Cushion rubber ⇒ Hammer spring ⇒ Spring fixing plate

balls may fall down.

4. Take out the pins something like a magnet and planet gears.

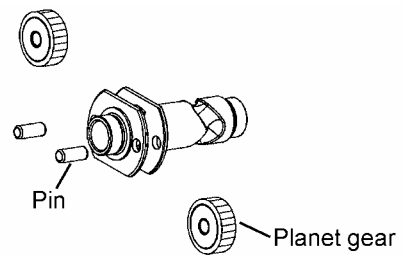

5.2. REASSEMBLY INSTRUCTIONS

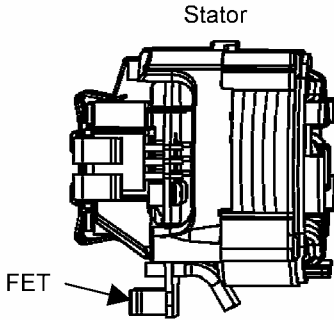
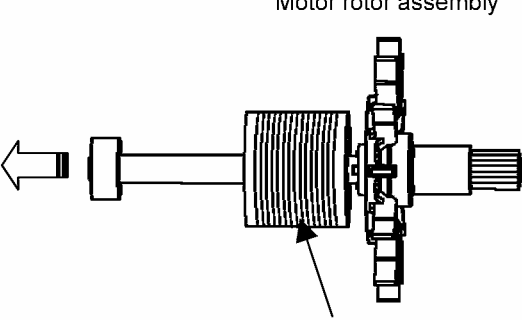
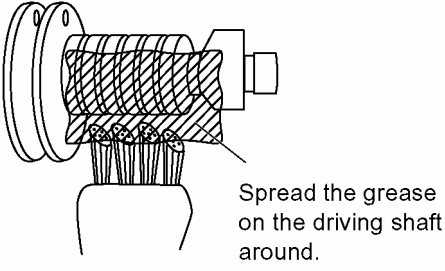
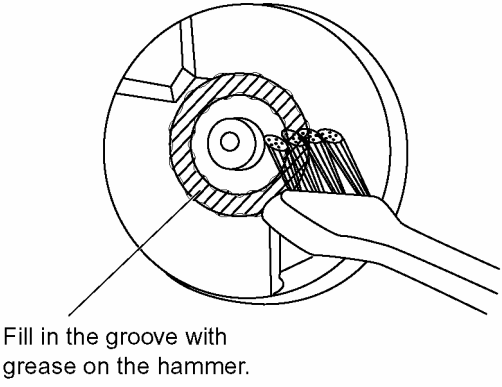
Ref. No. 2 A	Procedure 2A	Assembly of Motor.
		<ol style="list-style-type: none"> 1. Confirm if the metal powder is stuck around the rotor. If so, take out by something like packaging tape. 2. Insert the motor rotor into the stator.
		<p>Confirm there is no metal powder stuck around.</p>
Ref. No. 2 B	Procedure 2A→2B	Assembly of Driving shaft assembly.
		<ol style="list-style-type: none"> 1. Assemble the individual part in reverse order of disassembly. 2. Apply the grease (ASG22 / WEY6811X5537) for EYFLA1 & EYFLA2 or the grease (WEYFLA3JX557) for EYFLA3 on the hammer and the driving shaft.
		

Ref. No. 2C	Procedure 2A→2B→2C	Assembly of Module assembly.
-------------	--------------------	------------------------------

1. Set the DIP switch on the main circuit board with a toothpick.
- NOTE:** Do not use a metal pick.
Condition varies with the torque (by model).

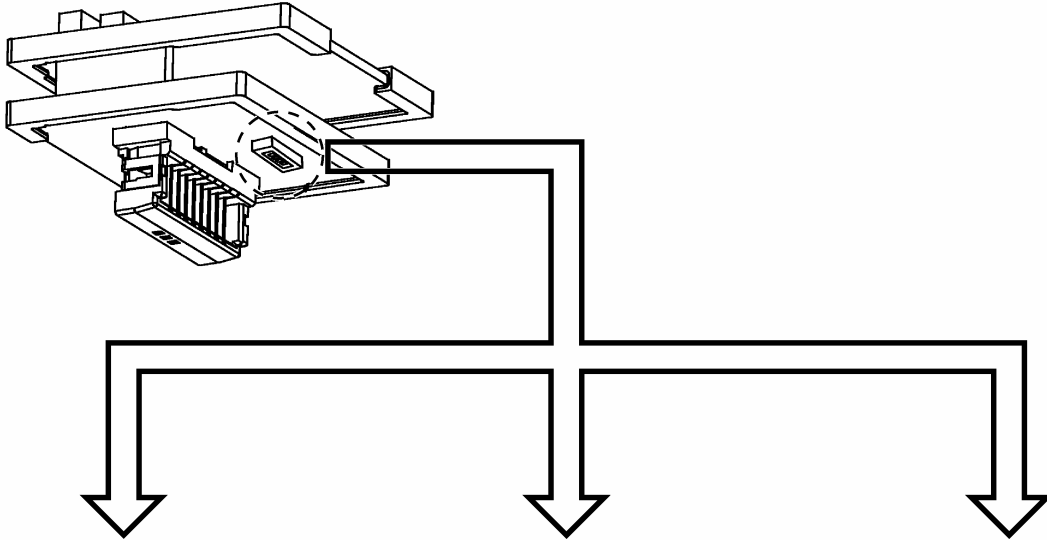

Model: EYFLA1	Model: EYFLA2	Model: EYFLA3																																																												
<p><condition></p> <table border="1"> <tr> <td>1</td> <td>OFF</td> <td>1</td> <td></td> <td>0</td> </tr> <tr> <td>2</td> <td>ON</td> <td>2</td> <td></td> <td>N</td> </tr> <tr> <td>3</td> <td>OFF</td> <td>3</td> <td></td> <td>7</td> </tr> <tr> <td>4</td> <td>OFF</td> <td>4</td> <td></td> <td>0</td> </tr> </table> <p>Replacement part is set on this condition.</p>	1	OFF	1		0	2	ON	2		N	3	OFF	3		7	4	OFF	4		0	<p><condition></p> <table border="1"> <tr> <td>1</td> <td>OFF</td> <td>1</td> <td></td> <td>0</td> </tr> <tr> <td>2</td> <td>OFF</td> <td>2</td> <td></td> <td>N</td> </tr> <tr> <td>3</td> <td>ON</td> <td>3</td> <td></td> <td>7</td> </tr> <tr> <td>4</td> <td>OFF</td> <td>4</td> <td></td> <td>0</td> </tr> </table> <p>When the module assembly replaced with new parts, the condition should be adjusted.</p>	1	OFF	1		0	2	OFF	2		N	3	ON	3		7	4	OFF	4		0	<p><condition></p> <table border="1"> <tr> <td>1</td> <td>OFF</td> <td>1</td> <td></td> <td>0</td> </tr> <tr> <td>2</td> <td>OFF</td> <td>2</td> <td></td> <td>N</td> </tr> <tr> <td>3</td> <td>OFF</td> <td>3</td> <td></td> <td>7</td> </tr> <tr> <td>4</td> <td>ON</td> <td>4</td> <td></td> <td>0</td> </tr> </table> <p>When the module assembly replaced with new parts, the condition should be adjusted.</p>	1	OFF	1		0	2	OFF	2		N	3	OFF	3		7	4	ON	4		0
1	OFF	1		0																																																										
2	ON	2		N																																																										
3	OFF	3		7																																																										
4	OFF	4		0																																																										
1	OFF	1		0																																																										
2	OFF	2		N																																																										
3	ON	3		7																																																										
4	OFF	4		0																																																										
1	OFF	1		0																																																										
2	OFF	2		N																																																										
3	OFF	3		7																																																										
4	ON	4		0																																																										

Model EYFLA1/EYFLA2/EYFLA3

Ref. No. 2D	Procedure 2A→2B→2C→2D	Assembly of Switch and Motor assembly.
-------------	-----------------------	--

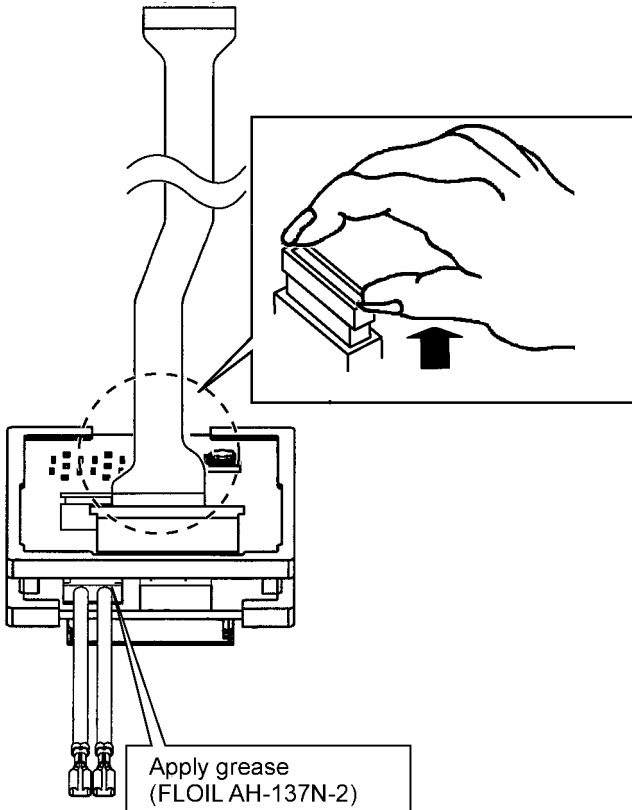

1. Attach the quick connect terminal of the white lead wire from the motor stator with the switch assembly (M+).
2. Apply grease (FLOIL AH-137N-2 / WEWGW2) on the both side and both end of ribbon cable where insert into the connectors.
NOTE: Confirm if there is no dust or any foreign substances.
3. Slightly lift the connector up.
NOTE: Do not pull the connector forcefully. It does not separate from the other connector.
4. Insert the ribbon cable into the motor stator and the main PCB.
NOTE: Make sure to handle the ribbon cable gently in order to avoid the breakage.
5. Insert the quick connect terminal of motor lead wire (black) into the (-) side of terminal block.
6. Insert the connector of harness into the main PCB.
7. Connect the black lead wire into the (-) side of terminal block and the read lead wire goes to (+) side of terminal block.

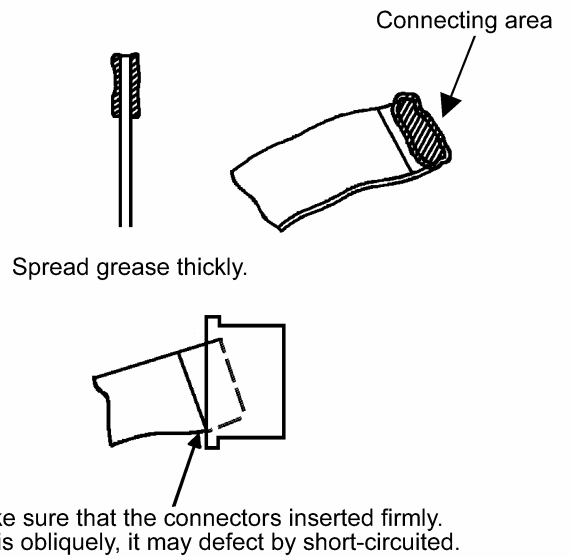
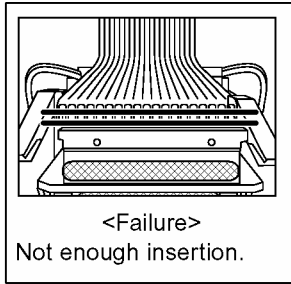
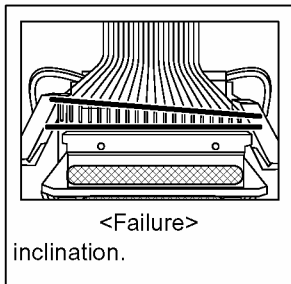
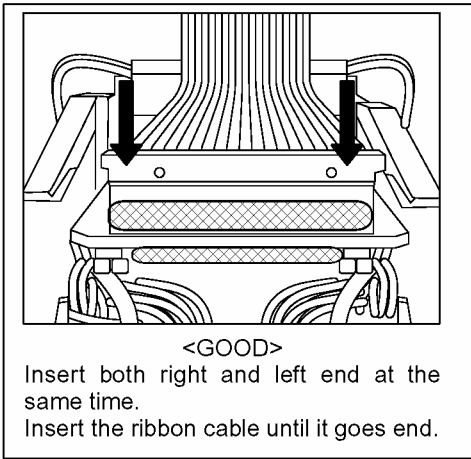

Ref. No. 2E	Procedure 2A→2B→2C→2D→2E	Assembly of Driving assembly.
-------------	--------------------------	-------------------------------

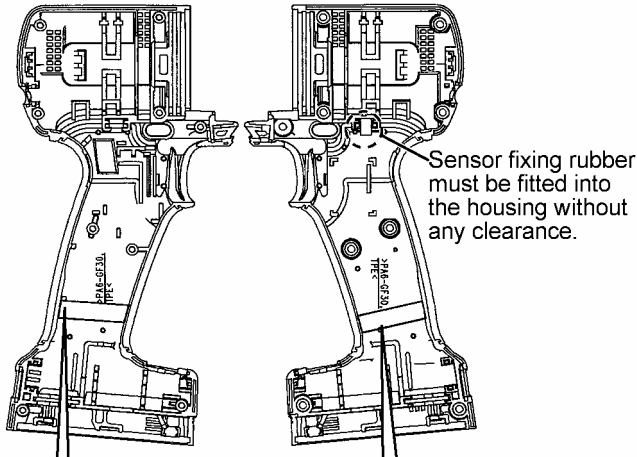

1. Attach Cushion B on both Housing A and B.
 2. Confirm to attach the fixing rubber on Housing B.
 3. Insert the motor and driving shaft assembly into the housing.
 4. Confirm to set the motor lead wire (red) under the black lead wire and confirm if there is no pinching with switch.
 5. Place the battery terminal lead wire (black) is over the wire (red) properly.
- NOTE:** Press fit the lead wires firmly.
Place the ribbon cable properly without getting caught in the lead wires.
6. Set the cushion A.

Cushion B is sticking along with rib bottom

Cushion B is sticking on the material display bottom

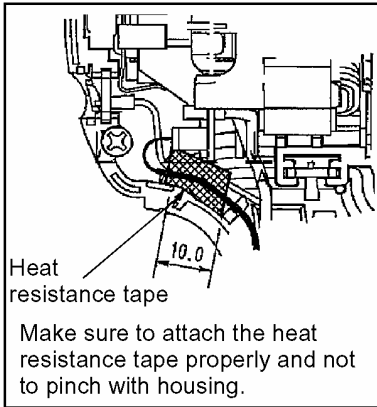

Make a curve (R1 and R2) on ribbon cable before attaching into connector.

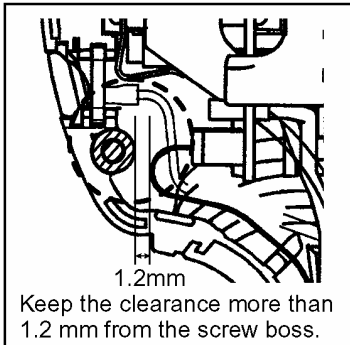

Press fit the ribbon cable firmly.

There are anti-vibration rubber on top and bottom. Confirm if the motor block set firmly.

Insert the quick connect terminal straight.

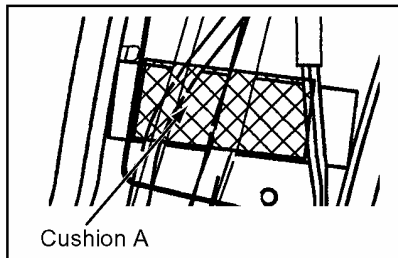

Cushion A

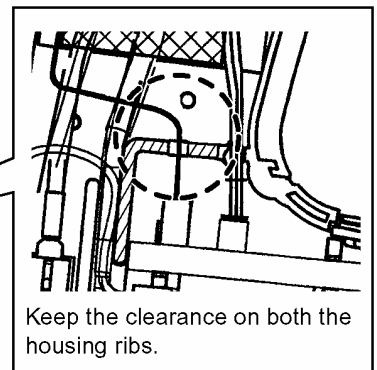

Lead wire between battery terminal and Main PCB.
Black: (-) upper
Red: (+) lower

Apply the grease.
Adjust the DIP switch.

Model EYFLA1/EYFLA2/EYFLA3

Ref. No. 2F	Procedure 2A→2B→2C→2D→2E→2F	Assembly of Driving assembly.
-------------	-----------------------------	-------------------------------

1. Close the housing A and B.
2. Tighten nine housing screws.
3. Apply the grease (THIXO NLG1#2 / WEY6813X5517) all around the anvil.
4. Assemble the slider to the clutch handle. Confirm it has its own direction.
5. Place the anvil into the clutch handle
6. Apply the grease (ASG22 / WEY6811X5537) for EYFLA1 & EYFLA2 or the grease (WEYFLA3JX557) for EYFLA3 on the rear side of fixation cover.
7. Attach the fixation cover.
8. Tighten four screws.

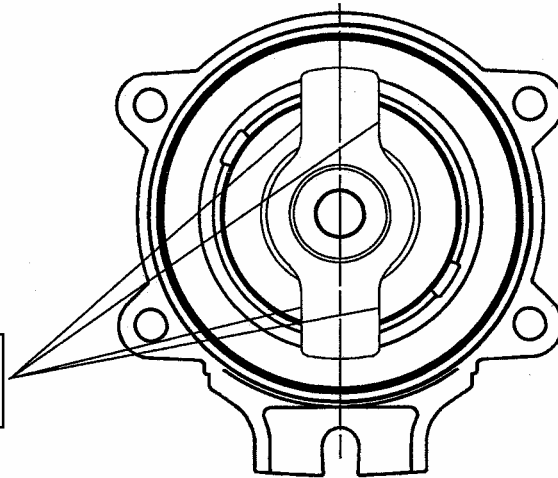

Apply the grease (THIXO NLG1#2) about $\phi 5$ amount on the side of power shaft.
(Place where the hammer hits.)

Slider has its own direction.

Apply the grease to the sliding surface of the driving shaft about 1.0mm thickness.

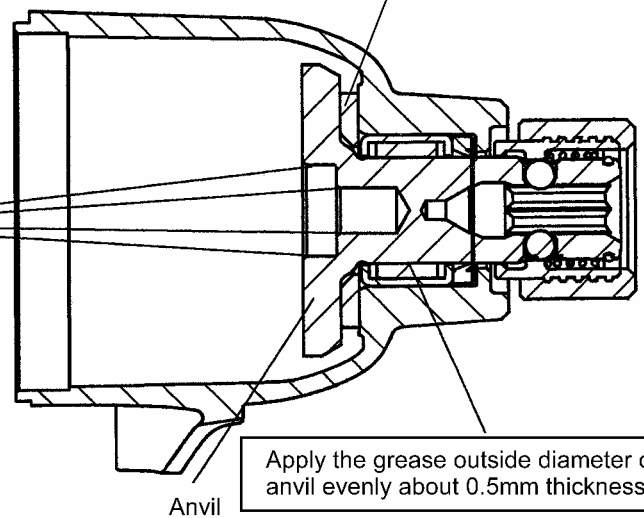

Apply the grease outside diameter of anvil evenly about 0.5mm thickness.

6. MEASUREMENTS and ADJUSTMENTS

6.1. TRIAL OPERATION (after checking TROUBLESHOOTING GUIDE.)

A. ASSEMBLY

- Confirm if there is NO gap between Housing A and B by pinching the lead wires.
- Confirm all screws are tightened firmly.
- Confirm if there is no deformation on the battery terminal.

B. OPERATION

- Confirm if SWITCH and LED turn ON and OFF.
- Confirm if F/R selector handle works smoothly and their rotation.
- Change the rotation speed in proportion to the amount of pushing level on switch trigger.
- There should be no metallic sound and abnormal sound when shaking up-down and right-left.
- There should be no abnormal vibration.

C: TOOL SETTING

- Engage the switch briefly to reactivate the display and select the model by pressing the remote control.
- Confirm if all lamps are lit for one second and indicate the proper display for three seconds.

Display	Tool circuit
H2	EYFLA1
H3	EYFLA2
H4	EYFLA3

D: TORQUE SETTING

Every unit must be measured the torque value on the following condition for 5 times. Confirm if the dispersion of torque is in the appropriate range or compare their average value with the new unit (or close condition of new unit).

Model	Bolt	Torque clutch setting
EYFLA1	M6	11
EYFLA2	M6	2
EYFLA3	M8	3

7. SCHEMATIC DIAGRAM

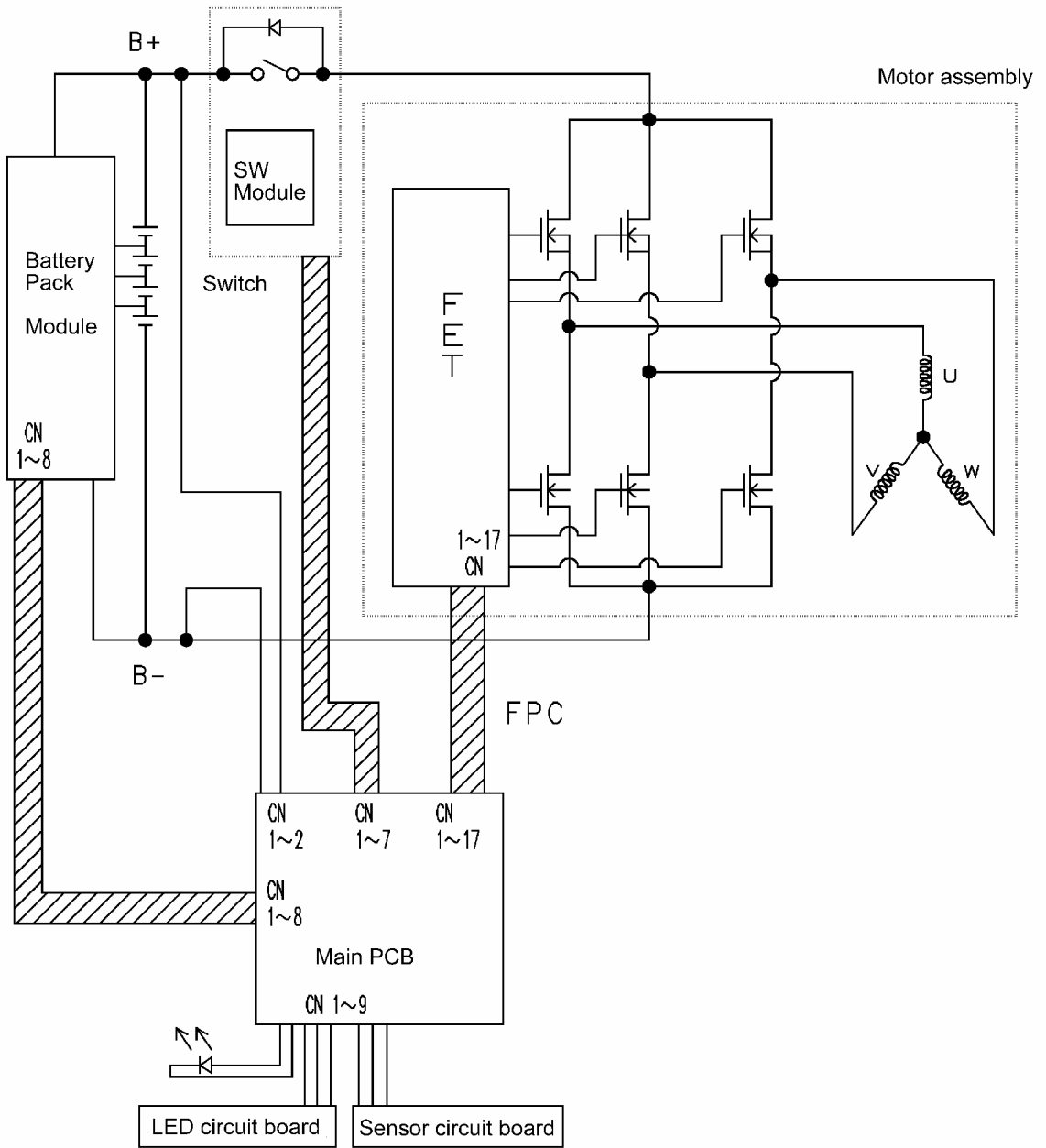

8. WIRING CONNECTION DIAGRAM

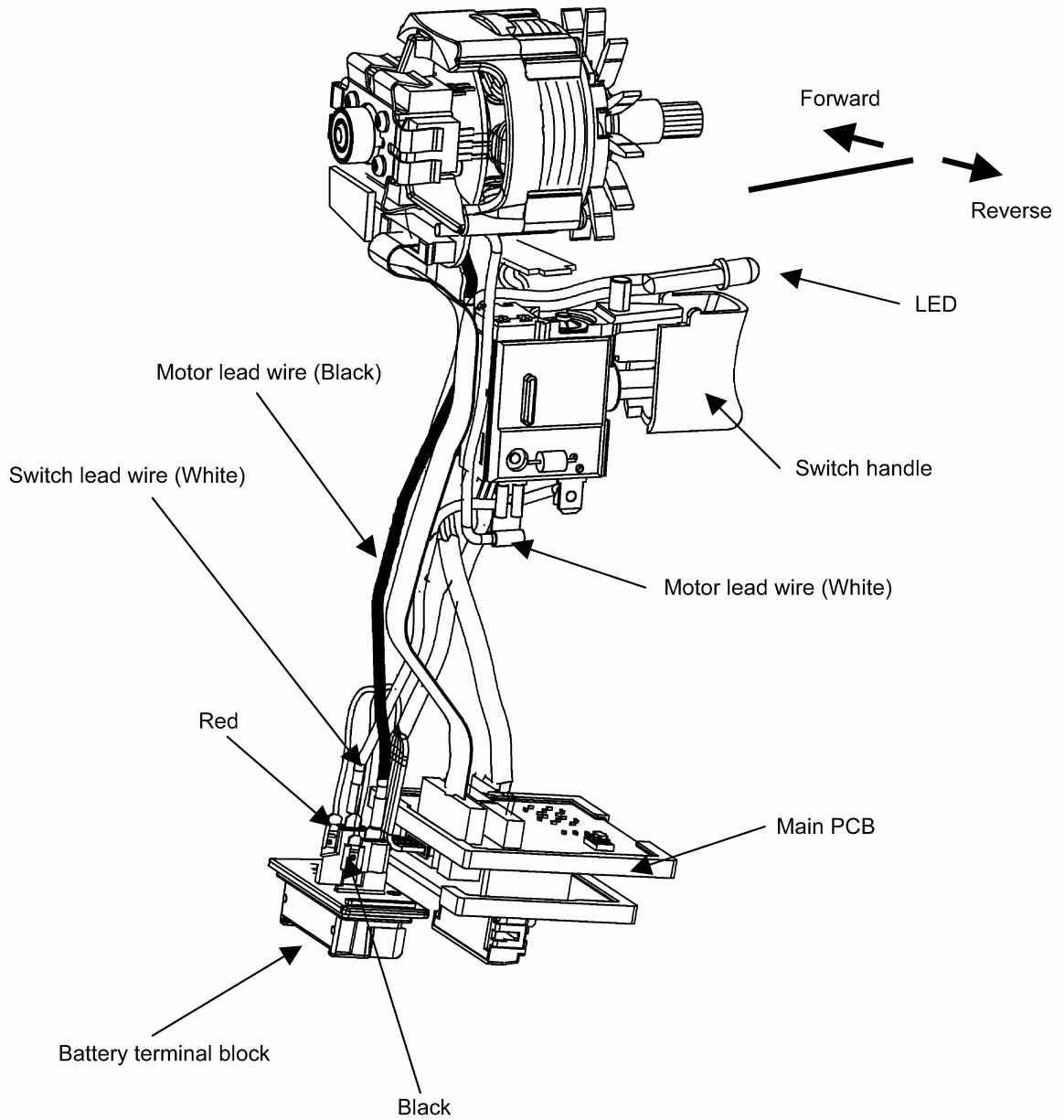

Model EYFLA1/EYFLA2/EYFLA3

9. EXPLODED VIEW & REPLACEMENT PARTS LIST

9.1. EXPLODED VIEW for EYFLA1A

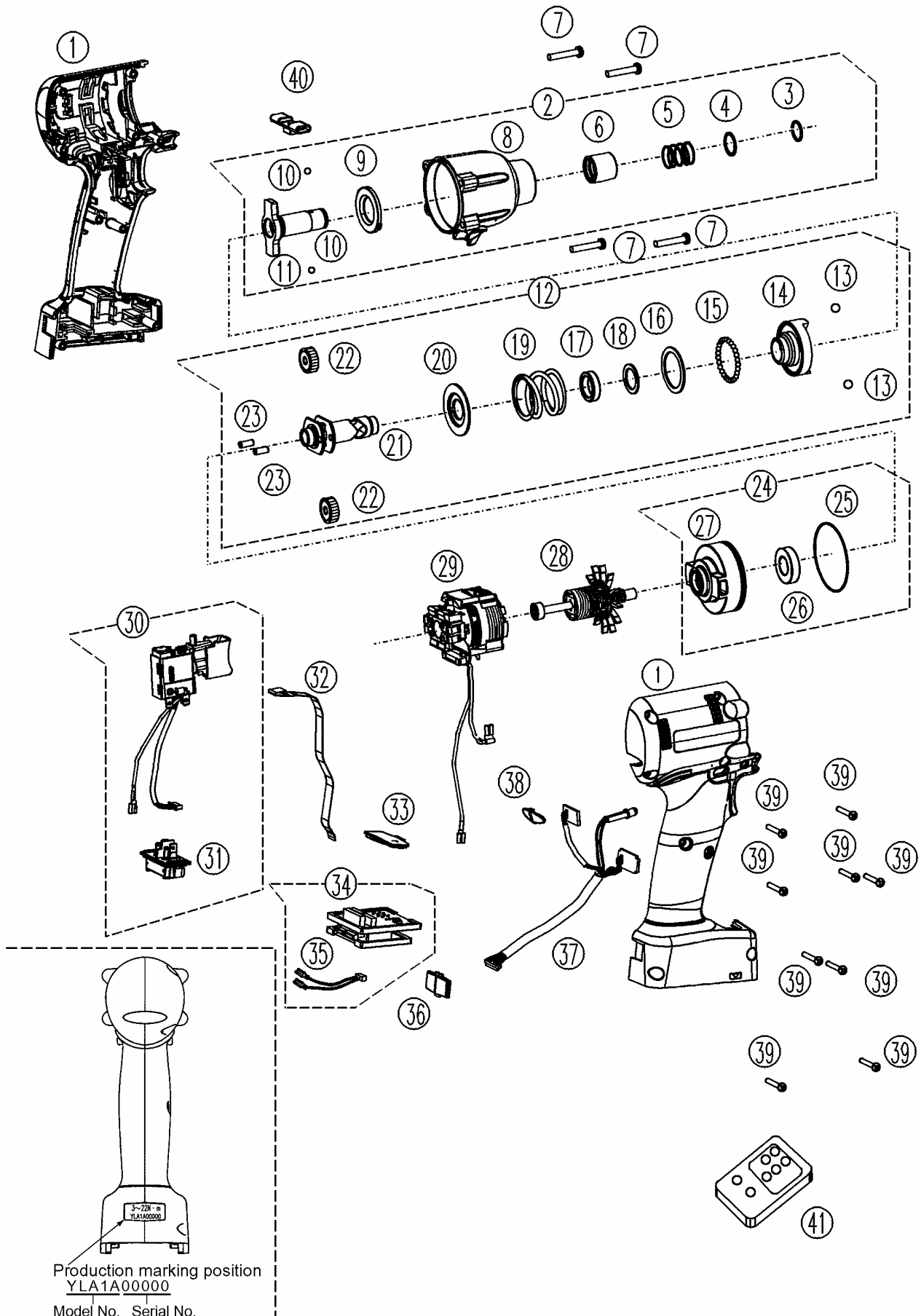

** Battery Pack is available as an optional accessory. See the nearest sales dealer for details.

*** For replacement parts of charger, see the charger service manual.

Charger complete set is available as an optional accessory. See the nearest sales dealer for details.

9.2. REPLACEMENT PARTS LIST for EYFLA1A

Ref. No.	Part No.	Part Name & Descriptions	Qty	Remarks
1	WEYFLA1AK300	HOUSING AB SET	1	
2	WEYFLA1AK407	FIXATION COVER ASSEMBLY	1	
3	WEY6507K1166	C-TYPE RING	1	
4	WEY6505L0866	SLIDER	1	
5	WEY6507L0196	BIT HOLDER SPRING	1	
6	WEYFLA1AK377	BIT HOLDER	1	
7	WEYFLA1AL967	SEMS SCREW	4	(4*22)
8	WEYFLA1AS317	FIXATION COVER	1	
9	WEY6507L0856	THRUST PLATE	1	
10	WEY6507L6976	STEEL BALL	2	(φ5/32), (2PCS/PK)
11	WEYFLA1AL127	ANVIL	1	
12	WEYFLA1AL107	DRIVING SHAFT ASSEMBLY	1	
13	WEY7201L6966	STEEL BALL	2	(7/32), (2PCS/PK)
14	WEYFLA1AL157	HAMMER	1	
15	WEY7205L6957	STEEL BALL	29	(29PCS/PK)
16	WEYFLA1AL087	THRUST PLATE	1	
17	WEYFLA1AL037	CUSHION RUBBER	1	
18	WEYFLA1AL097	THRUST PLATE	1	
19	WEYFLA1AL017	HAMMER SPRING	1	
20	WEYFLA1AL137	SPRING FIXING PLATE	1	
21	WEY7540L1137	DRIVING SHAFT	1	
22	WEY6504L1357	PLANET GEAR	2	(2PCS/PK)
23	WEY6506L1346	PIN	2	(2PCS/PK)
24	WEYFLA1AL007	MOTOR MOUNTING PLATE ASSEMBLY	1	
25	WEYT611L0967	O-RING	1	(43.6*1.3)
26	WEYFLA1AL497	BEARING	1	
27	WEY7205L0037	MOTOR MOUNTING PLATE	1	
28	WEYFLA1AL147	MOTOR ROTOR ASSEMBLY	1	
29	WEYFLA1AL117	STATOR	1	
30	WEYFLA1AK207	SWITCH ASSEMBLY	1	
31	WEY7540L2157	BATTERY TERMINAL BLOCK	1	
32	WEYFLA1AL207	RIBBON CABLE	1	
33	WEYFLA1AK337	OPERATION PANEL	1	
34	WEYFLA1AL217	MODULE ASSEMBLY	1	
35	WEYFLA1AL297	HARNESS	1	
36	WEYFLA1AL337	DISCERNMENT PLATE	1	
37	WEYFLA1AL227	LED ASSEMBLY	1	
38	WEYFLA1AL377	TIGHTENING CONFIRMATION LAMP COVER	1	
39	WEY6930K9037	TIGHT SCREW	9	(K3*20)
40	WEYFLA1AK327	F/R SELECTOR HANDLE	1	
41	WEYFA30B4450	REMOTE CONTROL	1	
-	WEYFLA1AK819	OPERATING INSTRUCTIONS	1	
-	WEYFLA1AK838	HEAT-RESISTANCE TAPE	1	(30M)
-	WEYFLA1AK848	RUBBER SHEET	1	(10PCS/PK), (for Stator)
-	WEYFLA1AK858	CUSHION A	1	(10PCS/PK), (for Housing)
-	WEYFLA1AK868	CUSHION B	2	(20PCS/PK), (for Housing)
-	WEYFLA1AK878	FIXING RUBBER	1	(10PCS/PK), (for Housing)
-	WEY6811X5537	GREASE (ASG-22)	1	(500g), (mainly for Hammer area)
-	WEY6813X5517	THIXO GREASE	1	(400g), (mainly for Anvil area)
-	WEWGW2	FLOIL GREASE	1	(5g), (mainly for Switch contacting area)

9.3. EXPLODED VIEW for EYFLA2A

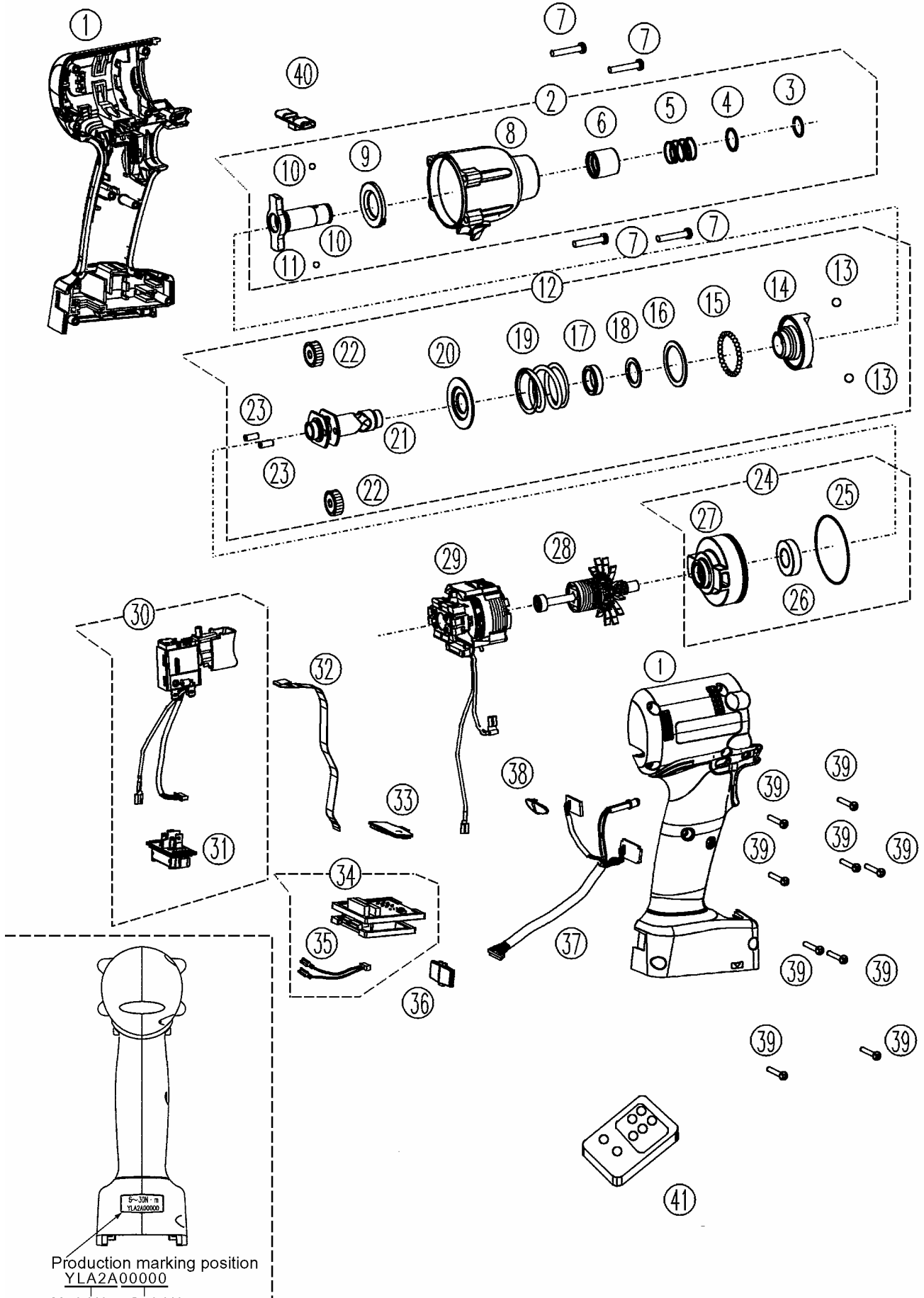

** Battery Pack is available as an optional accessory. See the nearest sales dealer for details.

*** For replacement parts of charger, see the charger service manual.

Charger complete set is available as an optional accessory. See the nearest sales dealer for details.

9.4. REPLACEMENT PARTS LIST for EYFLA2A

Ref. No.	Part No.	Part Name & Descriptions	Qty	Remarks
1	WEYFLA2AK300	HOUSING AB SET	1	
2	WEYFLA1AK407	FIXATION COVER ASSEMBLY	1	
3	WEY6507K1166	C-TYPE RING	1	
4	WEY6505L0866	SLIDER	1	
5	WEY6507L0196	BIT HOLDER SPRING	1	
6	WEYFLA1AK377	BIT HOLDER	1	
7	WEYFLA1AL967	SEMS SCREW	4	(4*22)
8	WEYFLA1AS317	FIXATION COVER	1	
9	WEY6507L0856	THRUST PLATE	1	
10	WEY6507L6976	STEEL BALL	2	(ϕ 5/32), (2PCS/PK)
11	WEYFLA1AL127	ANVIL	1	
12	WEYFLA2NL107	DRIVING SHAFT ASSEMBLY	1	
13	WEY7201L6966	STEEL BALL	2	(7/32), (2PCS/PK)
14	WEYFLA2AL157	HAMMER	1	
15	WEY7205L6957	STEEL BALL	29	(29PCS/PK)
16	WEYFLA1AL087	THRUST PLATE	1	
17	WEYFLA1AL037	CUSHION RUBBER	1	
18	WEYFLA1AL097	THRUST PLATE	1	
19	WEYFLA2AL017	HAMMER SPRING	1	
20	WEYFLA1AL137	SPRING FIXING PLATE	1	
21	WEY7540L1137	DRIVING SHAFT	1	
22	WEY6504L1357	PLANET GEAR	2	(2PCS/PK)
23	WEY6506L1346	PIN	2	(2PCS/PK)
24	WEYFLA1AL007	MOTOR MOUNTING PLATE ASSEMBLY	1	
25	WEYT611L0967	O-RING	1	(43.6*1.3)
26	WEYFLA1AL497	BEARING	1	
27	WEY7205L0037	MOTOR MOUNTING PLATE	1	
28	WEYFLA1AL147	MOTOR ROTOR ASSEMBLY	1	
29	WEYFLA1AL117	STATOR	1	
30	WEYFLA1AK207	SWITCH ASSEMBLY	1	
31	WEY7540L2157	BATTERY TERMINAL BLOCK	1	
32	WEYFLA1AL207	RIBBON CABLE	1	
33	WEYFLA1AK337	OPERATION PANEL	1	
34	WEYFLA1AL217	MODULE ASSEMBLY	1	
35	WEYFLA1AL297	HARNESS	1	
36	WEYFLA2AL337	DISCERNMENT PLATE	1	
37	WEYFLA1AL227	LED ASSEMBLY	1	
38	WEYFLA1AL377	TIGHTENING CONFIRMATION LAMP COVER	1	
39	WEY6930K9037	TIGHT SCREW	9	(K3*20)
40	WEYFLA1AK327	F/R SELECTOR HANDLE	1	
41	WEYFA30B4450	REMOTE CONTROL	1	
-	WEYFLA1AK819	OPERATING INSTRUCTIONS	1	
-	WEYFLA1AK838	HEAT-RESISTANCE TAPE	1	(30M)
-	WEYFLA1AK848	RUBBER SHEET	1	(10PCS/PK), (for Stator)
-	WEYFLA1AK858	CUSHION A	1	(10PCS/PK), (for Housing)
-	WEYFLA1AK868	CUSHION B	2	(20PCS/PK), (for Housing)
-	WEYFLA1AK878	FIXING RUBBER	1	(10PCS/PK), (for Housing)
-	WEY6811X5537	GREASE (ASG-22)	1	(500g), (mainly for Hammer area)
-	WEY6813X5517	THIXO GREASE	1	(400g), (mainly for Anvil area)
-	WEWGW2	FLOIL GREASE	1	(5g), (mainly for Switch contacting area)

Model EYFLA1/EYFLA2/EYFLA3

9.5. EXPLODED VIEW for EYFLA2Q

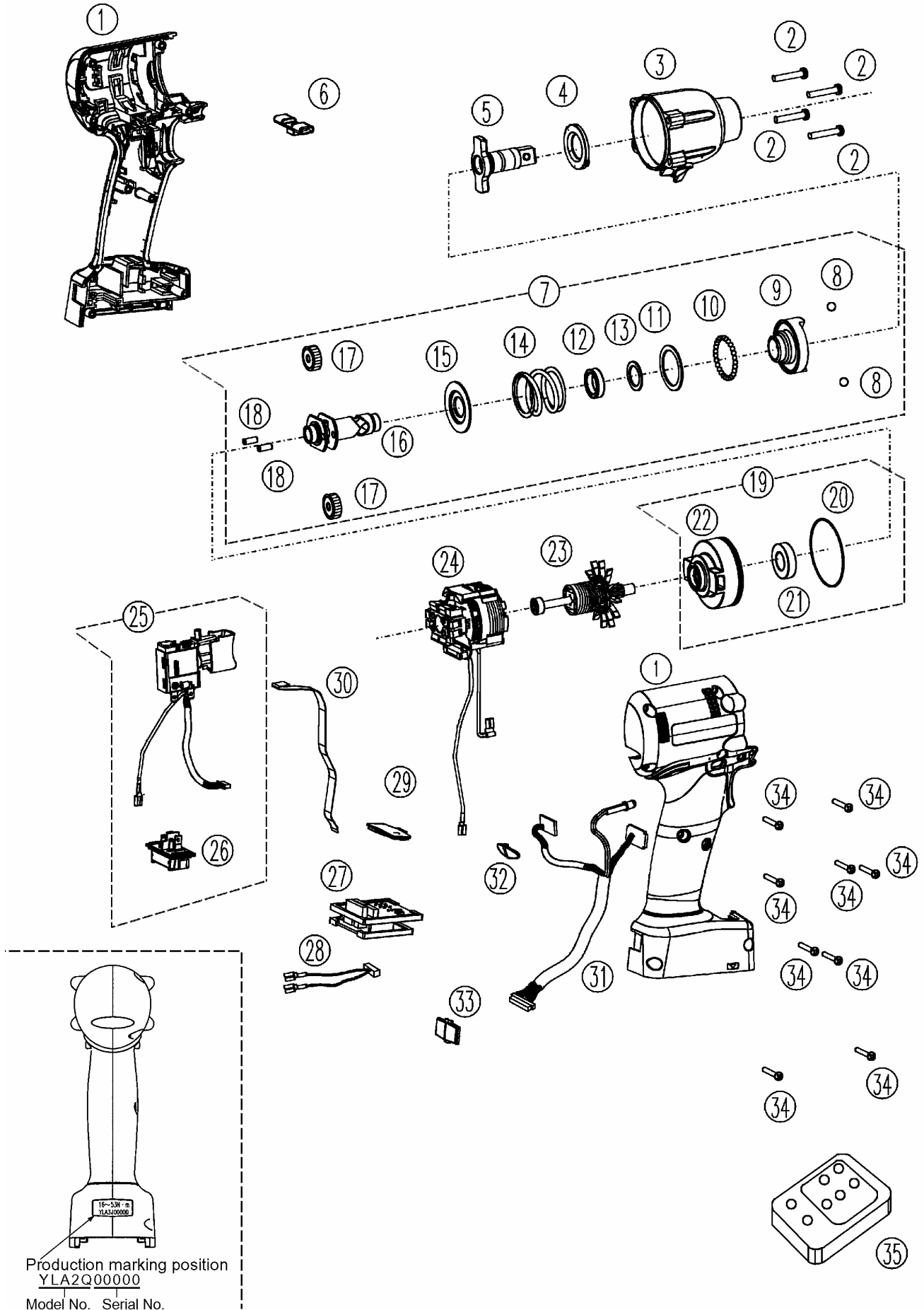

** Battery Pack is available as an optional accessory. See the nearest sales dealer for details.

*** For replacement parts of charger, see the charger service manual.

Charger complete set is available as an optional accessory. See the nearest sales dealer for details.

9.6. REPLACEMENT PARTS LIST for EYFLA2Q

Ref. No.	Part No.	Part Name & Descriptions	Qty	Remarks
1	WEYFLA2QK300	HOUSING AB SET	1	
2	WEYFLA1AL967	SEMS SCREW	4	(4*22)
3	WEYFLA1AS317	FIXATION COVER	1	
4	WEY6505L0866	SLIDER	1	
5	WEYFLA2QL127	ANVIL	1	
6	WEYFLA1AK327	F/R SELECTOR HANDLE	1	
7	WEYFLA2NL107	DRIVING SHAFT ASSEMBLY	1	
8	WEY7201L6966	STEEL BALL	2	(7/32), (2PCS/PK)
9	WEYFLA2AL157	HAMMER	1	
10	WEY7205L6957	STEEL BALL	29	(29PCS/PK)
11	WEYFLA1AL087	THRUST PLATE	1	
12	WEYFLA1AL037	CUSHION RUBBER	1	
13	WEYFLA1AL097	THRUST PLATE	1	
14	WEYFLA2AL017	HAMMER SPRING	1	
15	WEYFLA1AL137	SPRING FIXING PLATE	1	
16	WEY7540L1137	DRIVING SHAFT	1	
17	WEY6504L1357	PLANET GEAR	2	(2PCS/PK)
18	WEY6506L1346	PIN	2	(2PCS/PK)
19	WEYFLA1AL007	MOTOR MOUNTING PLATE ASSEMBLY	1	
20	WEYT611L0967	O-RING	1	(43.6*1.3)
21	WEYFLA1AL497	BEARING	1	
22	WEY7205L0037	MOTOR MOUNTING PLATE	1	
23	WEYFLA1AL147	MOTOR ROTOR ASSEMBLY	1	
24	WEYFLA1AL117	STATOR	1	
25	WEYFLA1AK207	SWITCH ASSEMBLY	1	
26	WEY7540L2157	BATTERY TERMINAL BLOCK	1	
27	WEYFLA1AL217	MODULE ASSEMBLY	1	
28	WEYFLA1AL297	HARNESS	1	
29	WEYFLA1AK337	OPERATION PANEL	1	
30	WEYFLA1AL207	RIBBON CABLE	1	
31	WEYFLA1AL227	LED ASSEMBLY	1	
32	WEYFLA1AL377	TIGHTENING CONFIRMATION LAMP COVER	1	
33	WEYFLA2AL337	DISCERNMENT PLATE	1	
34	WEY6930K9037	TIGHT SCREW	9	(K3*20)
35	WEYFA30B4450	REMOTE CONTROL	1	
-	WEYFLA1AK819	OPERATING INSTRUCTIONS	1	
-	WEYFLA1AK838	HEAT-RESISTANCE TAPE	1	(30M)
-	WEYFLA1AK848	RUBBER SHEET	1	(10PCS/PK), (for Stator)
-	WEYFLA1AK858	CUSHION A	1	(10PCS/PK), (for Housing)
-	WEYFLA1AK868	CUSHION B	2	(20PCS/PK), (for Housing)
-	WEYFLA1AK878	FIXING RUBBER	1	(10PCS/PK), (for Housing)
-	WEY6811X5537	GREASE (ASG-22)		(500g), (mainly for Hammer area)
-	WEY6813X5517	THIXO GREASE		(400g), (mainly for Anvil area)
-	WEWGW2	FLOIL GREASE		(5g), (mainly for Switch contacting area)

Model EYFLA1/EYFLA2/EYFLA3

9.7. EXPLODED VIEW for EYFLA3J

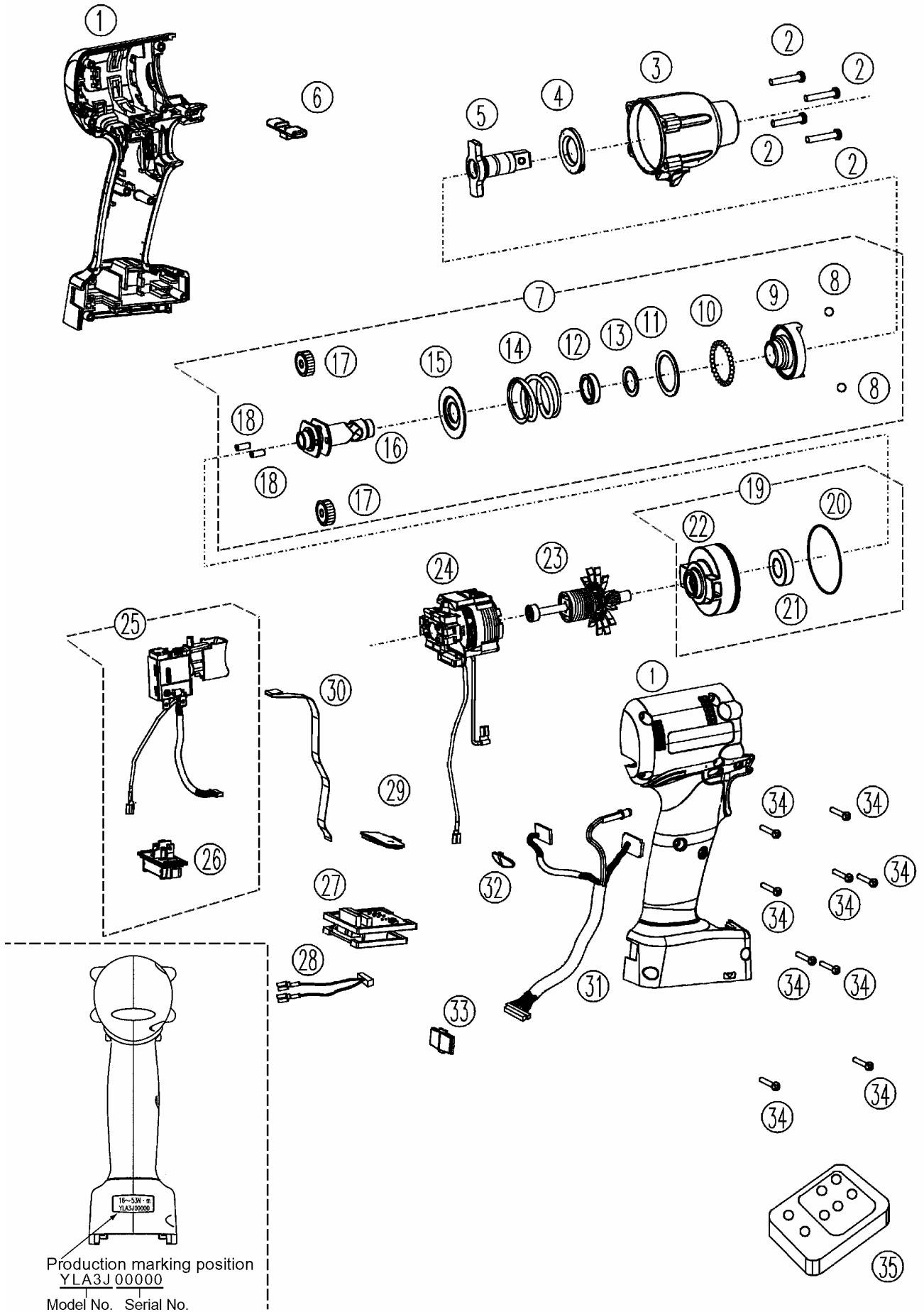

** Battery Pack is available as an optional accessory. See the nearest sales dealer for details.

*** For replacement parts of charger, see the charger service manual.

Charger complete set is available as an optional accessory. See the nearest sales dealer for details.

9.8. REPLACEMENT PARTS LIST for EYFLA3J

Ref. No.	Part No.	Part Name & Descriptions	Qty	Remarks
1	WEYFLA3JK300	HOUSING AB SET	1	
2	WEYFLA1AL967	SEMS SCREW	4	(4*22)
3	WEYFLA3JS317	FIXATION COVER	1	
4	WEY6631K0867	SLIDER	1	
5	WEYFLA3JL127	ANVIL	1	
6	WEYFLA1AK327	F/R SELECTOR HANDLE	1	
7	WEYFLA3JL107	DRIVING SHAFT ASSEMBLY	1	
8	WEY7201L6966	STEEL BALL	2	(7/32), (2PCS/PK)
9	WEYFLA3JL157	HAMMER	1	
10	WEY7205L6957	STEEL BALL	29	(29PCS/PK)
11	WEYFLA1AL087	THRUST PLATE	1	
12	WEYFLA3JL037	CUSHION RUBBER	1	
13	WEYFLA3JL087	THRUST PLATE	1	
14	WEY7541L0217	HAMMER SPRING	1	
15	WEY6508L1146	SPRING FIXING PLATE	1	
16	WEYFLA3JL137	DRIVING SHAFT	1	
17	WEY6504L1357	PLANET GEAR	2	(2PCS/PK)
18	WEY6506L1346	PIN	2	(2PCS/PK)
19	WEYFLA1AL007	MOTOR MOUNTING PLATE ASSEMBLY	1	
20	WEYT611L0967	O-RING	1	(43.6*1.3)
21	WEYFLA1AL497	BEARING	1	
22	WEY7205L0037	MOTOR MOUNTING PLATE	1	
23	WEYFLA1AL147	MOTOR ROTOR ASSEMBLY	1	
24	WEYFLA1AL117	STATOR	1	
25	WEYFLA1AK207	SWITCH ASSEMBLY	1	
26	WEY7540L2157	BATTERY TERMINAL BLOCK	1	
27	WEYFLA1AL217	MODULE ASSEMBLY	1	
28	WEYFLA1AL297	HARNESS	1	
29	WEYFLA1AK337	OPERATION PANEL	1	
30	WEYFLA1AL207	RIBBON CABLE	1	
31	WEYFLA3JL227	LED ASSEMBLY	1	
32	WEYFLA1AL377	TIGHTENING CONFIRMATION LAMP COVER	1	
33	WEYFLA3JL337	DISCERNMENT PLATE	1	
34	WEY6930K9037	TIGHT SCREW	9	(K3*20)
35	WEYFA30B4450	REMOTE CONTROL	1	
-	WEYFLA1AK819	OPERATING INSTRUCTIONS	1	
-	WEYFLA1AK838	HEAT-RESISTANCE TAPE	1	(30M)
-	WEYFLA1AK848	RUBBER SHEET	1	(10PCS/PK), (for Stator)
-	WEYFLA1AK858	CUSHION A	1	(10PCS/PK), (for Housing)
-	WEYFLA1AK868	CUSHION B	2	(20PCS/PK), (for Housing)
-	WEYFLA1AK878	FIXING RUBBER	1	(10PCS/PK), (for Housing)
-	WEYFLA3JX557	GREASE		(100g), (mainly for Hammer area)
-	WEY6813X5517	THIXO GREASE		(400g), (mainly for Anvil area)
-	WEWGW2	FLOIL GREASE		(5g), (mainly for Switch contacting area)